

Wellcome to you all..

History & Main Application Fields of Finite Element Methods

Prepared by:Hamdi Tekin

History

- The need for solving complex elasticity and structural analysis problems in civil and aeronautical engineering.
- Alexander Hrennikoff (1941) and Richard Courant (1942).
- Mesh discretization of a continuous domain into a set of discrete sub-domains, usually called elements

- Development in 1950s
- Airframe and structural analysis
- University of Stuttgart through the work of John Argyris
- At Berkeley through the work of Ray W. Clough in the 1960s for use in civil engineering.

- The key concepts of stiffness matrix and element assembly existed essentially in the form used today
- NASA issued request for proposals for the development of the finite element software NASTRAN in 1965

- The method was provided with a rigorous mathematical foundation in 1973 with the publication of Strang and Fix's *An Analysis of The Finite Element Method*[6], and has since been generalized into a branch of applied mathematics for numerical modeling of physical systems in a wide variety of engineering disciplines

Main Application Fields of FEM

Hydrolic and Water Resources Engineering

- The analysis of permeable layers carrying groundwater
- The analysis of water cycle in lakes and thermal analysis
- The analysis of channel flows

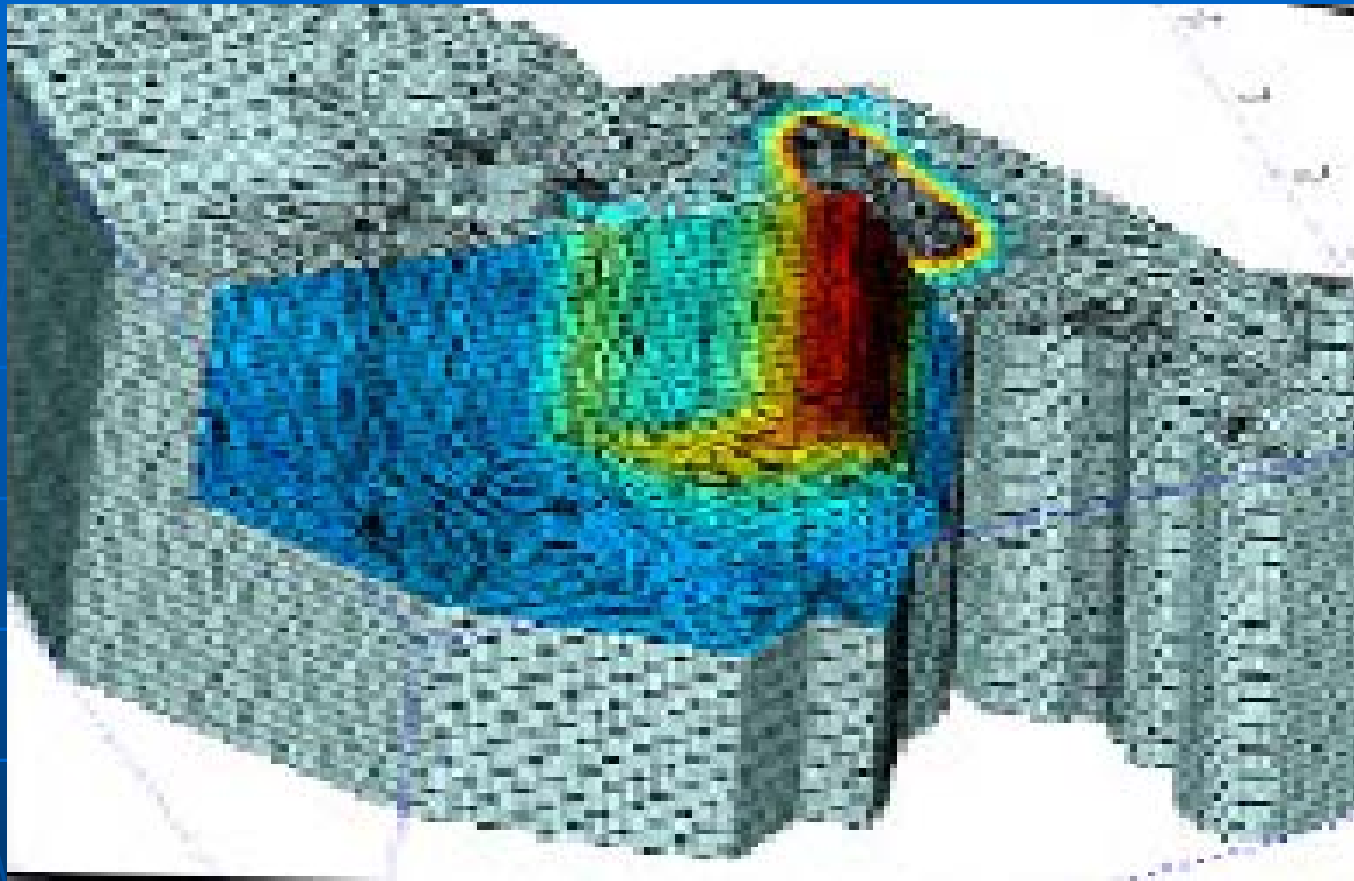

Finite model of groundwater flow

Soil Mechanics

- Tension analysis for the slope, excavation and sets.
- Rock mechanics: analysis of the holes of tunnels, mines, wells and cavities

Plaxis 3D Tunnel 2.0 Introductory Output - [qqq.003]

File Edit View Geometry Deformations Stresses Window Help



Front Plane | (Subplane 1) | Plane A | (Subplane A1) | Plane B | (Subplane B1) | Plane C | (Subplane C1) | (Subplane C2) | (Subplane C3) | Rear Plane | 3D

Introductory Version

Introductory Ve

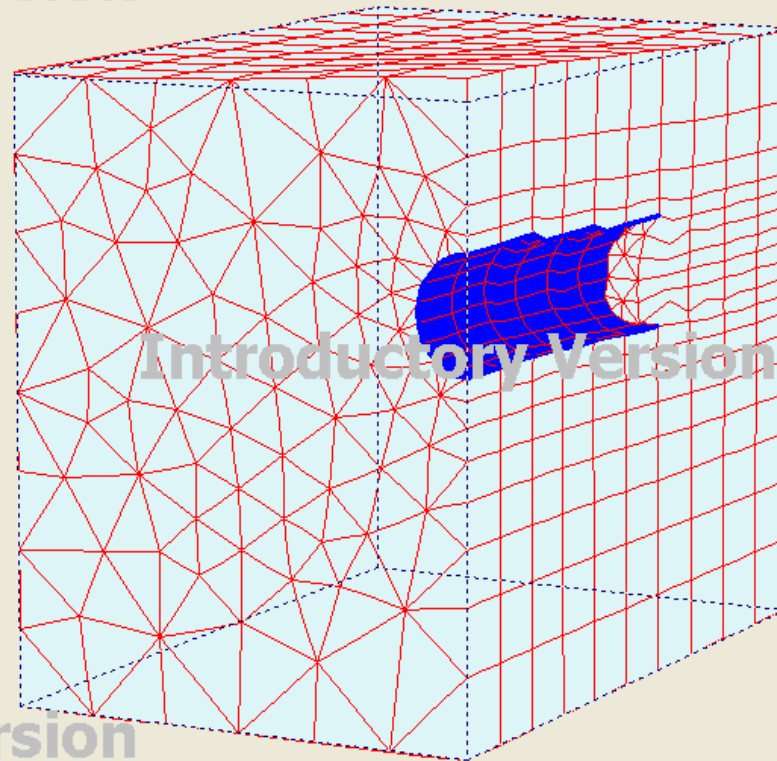

Introductory Version

Introductory Version

Introductory Ve

Deformed Mesh

Extreme total displacement $262,31 \cdot 10^{-3}$ m
(displacements scaled up 20,00 times)

3D Parallel planes

Plaxis 3D Tunnel 2.0 Introductory Output - [qqq.003 - Cross Section A - A*]

File Edit View Deformations Stresses Window Help

Deformations plane

Front Plane (Subplane 1) Plane A (Subplane A1) Plane B (Subplane B1) Plane C (Subplane C1) (Subplane C2) (Subplane C3) Rear Plane 3D

Introductory Version

Introductory Ve



Introductory Version

Introductory Version

Introductory Ve

Total displacements Utot

Extreme Utot $257,56 \cdot 10^{-3}$ m

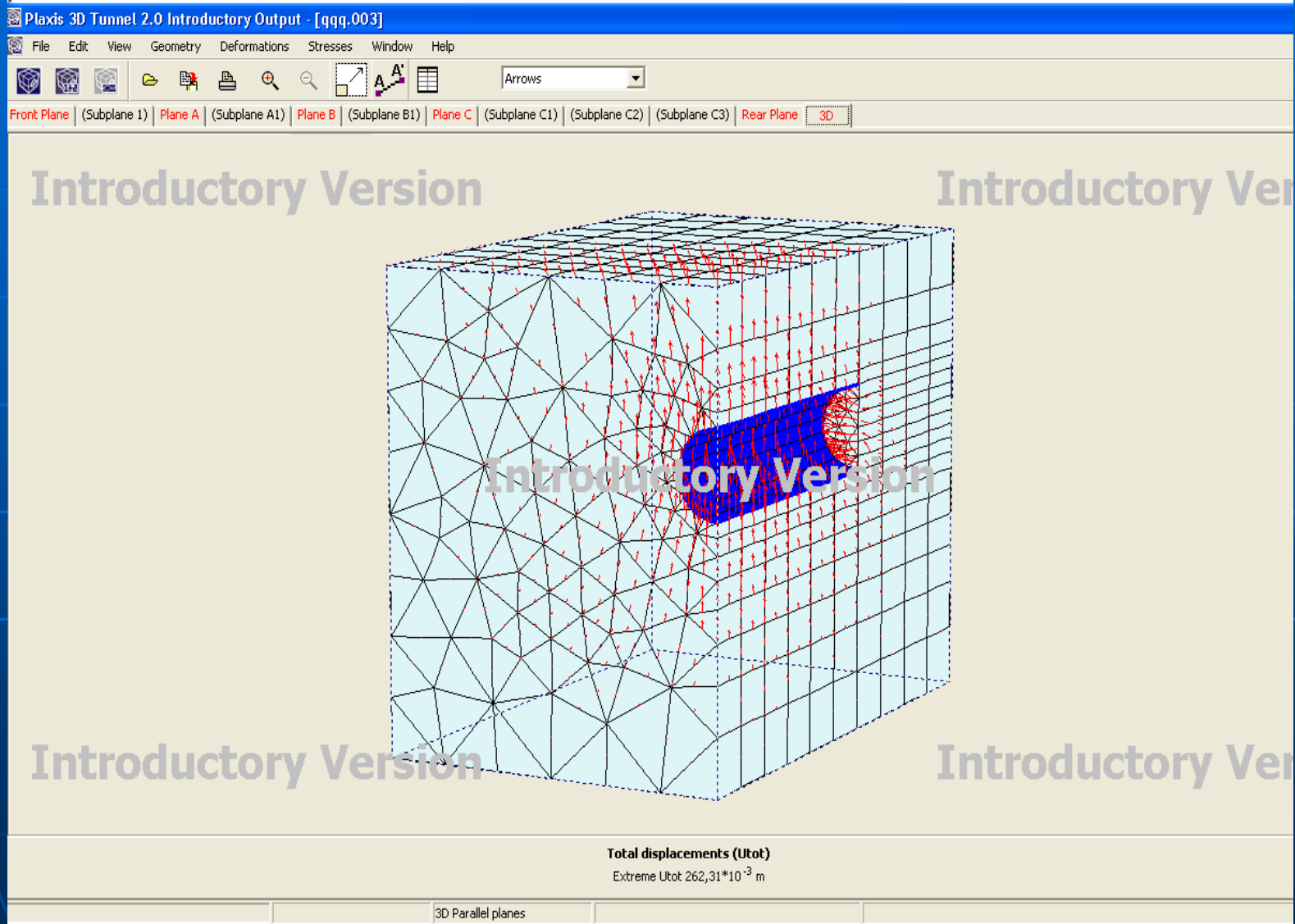

- Drawing
- Material Sets
- Boundary Conditions
- 2-D Meshing
- 3-D Meshing
- Initial Conditions
- Calculation

Hidroelasticity

- The motion of the liquids in elastic vessels.
- The analysis of the interaction between dam body and lake.

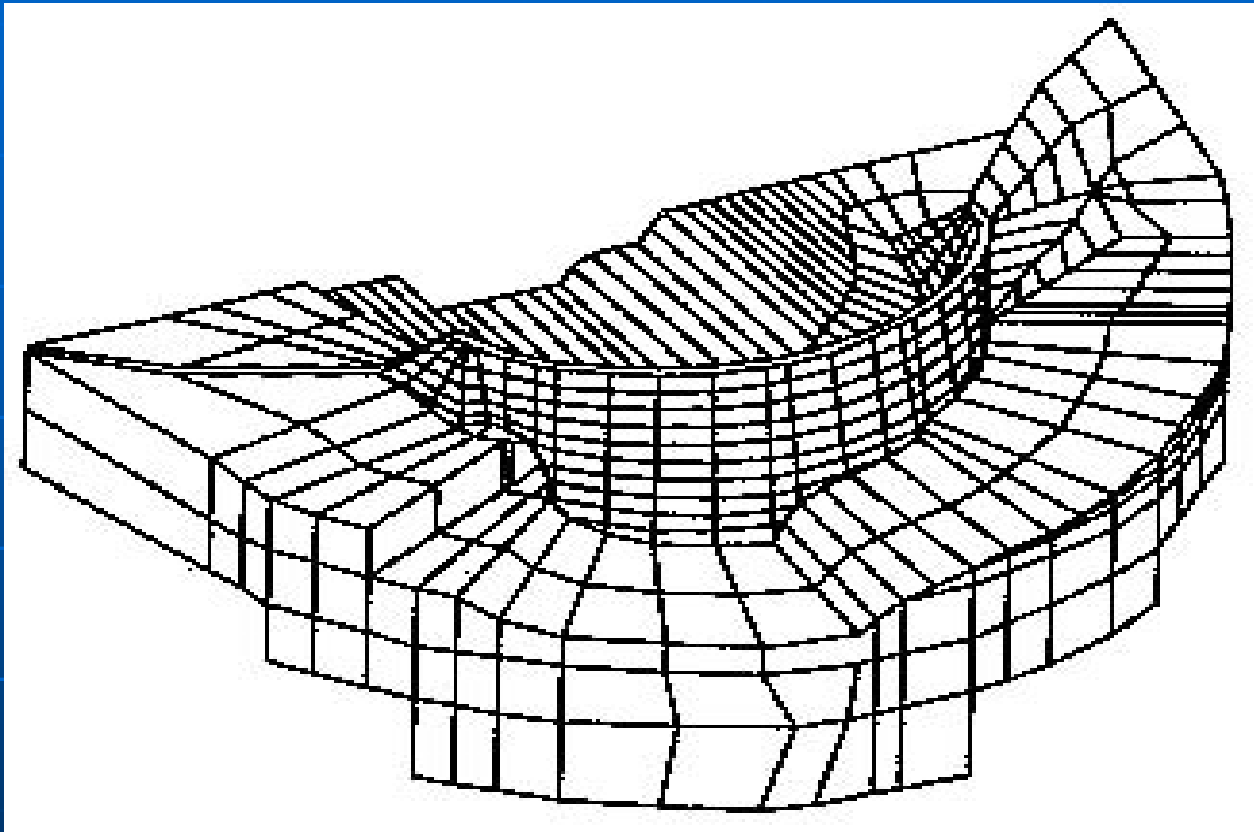

Finite element model of a dam body

Structural Engineering

- Deformation and stress distribution analysis
- Calculation of the tension density factors
- Analysis of the fracture progress

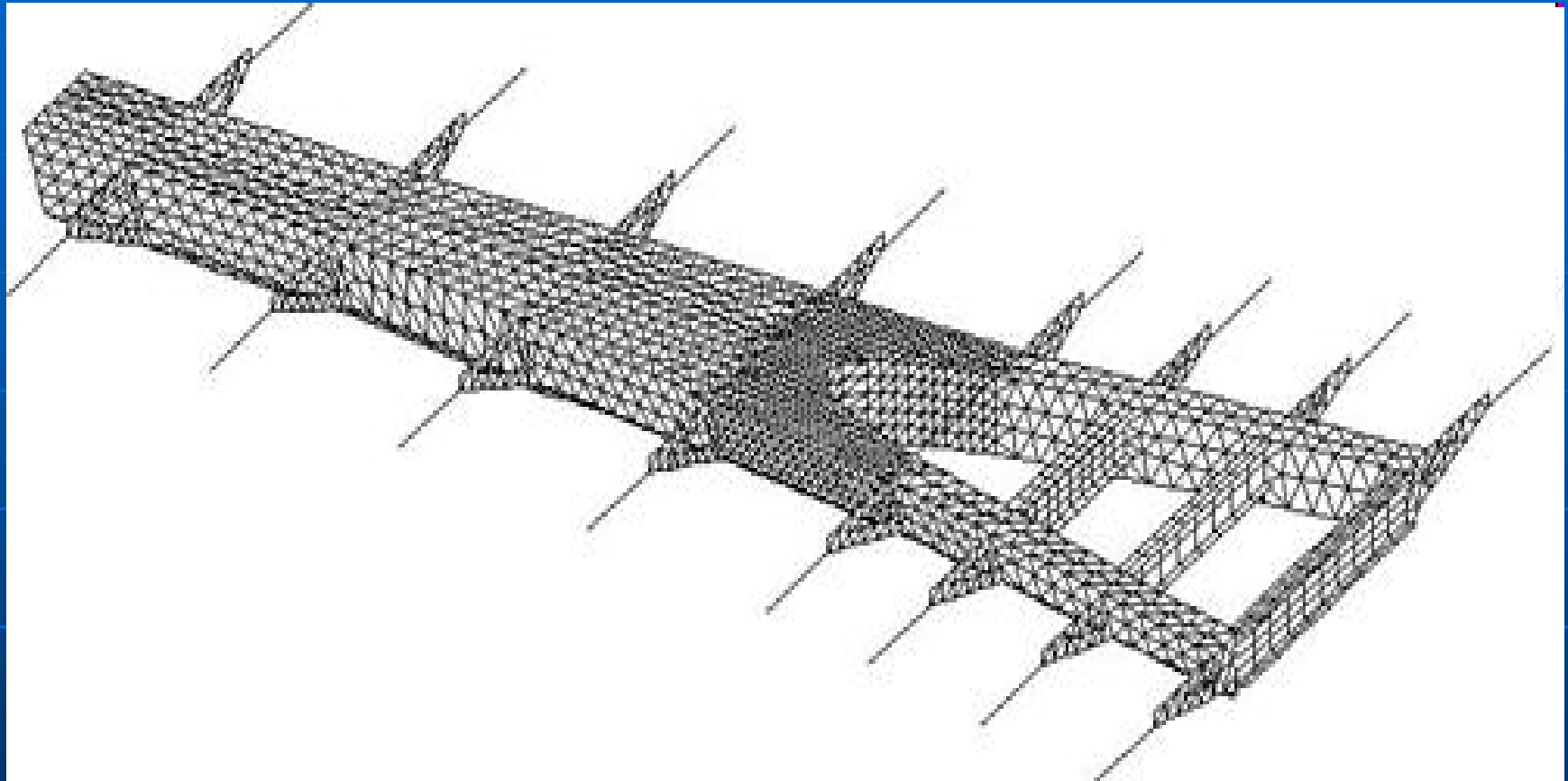

A foot bridge(half structure)

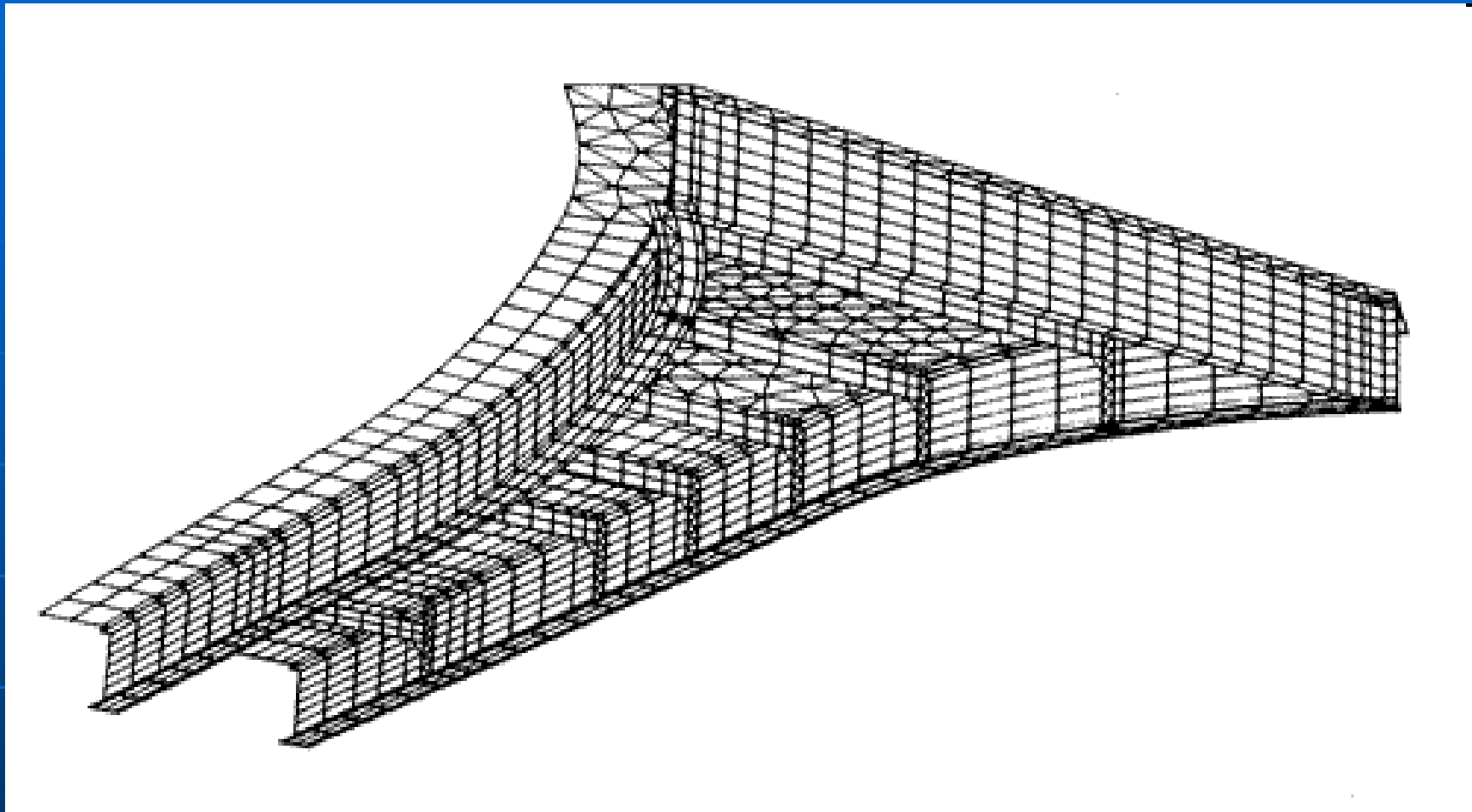

The Mirebeau Bridge, over the Durance River (in the south of France)

Automotive

- Analysis of the automobile body
- Analysis of the crashes

S-Y.CHEN@FEA-OPTIMIZATION.COM 200410
Time = 0

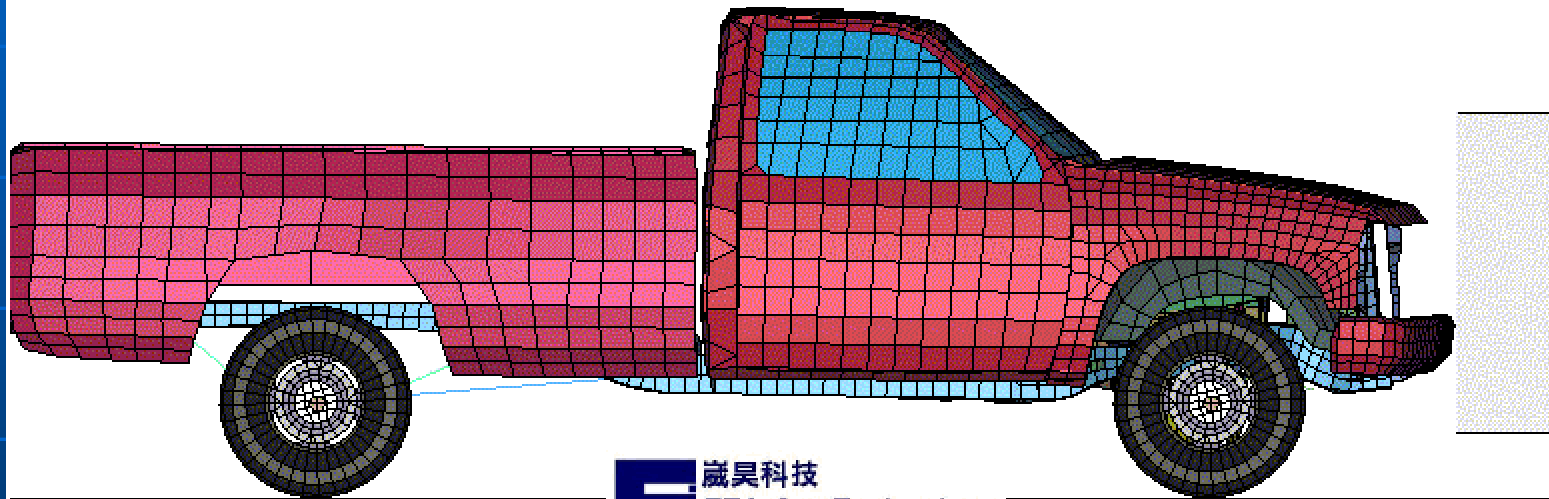

 崑崙科技
FEA-Opt Technology
www.FEA-Optimization.com
研發·顧問·CAE ··· R&D · Consultancy · CAE

Electrical Engineering

- The analysis of the electric and magnetic fields

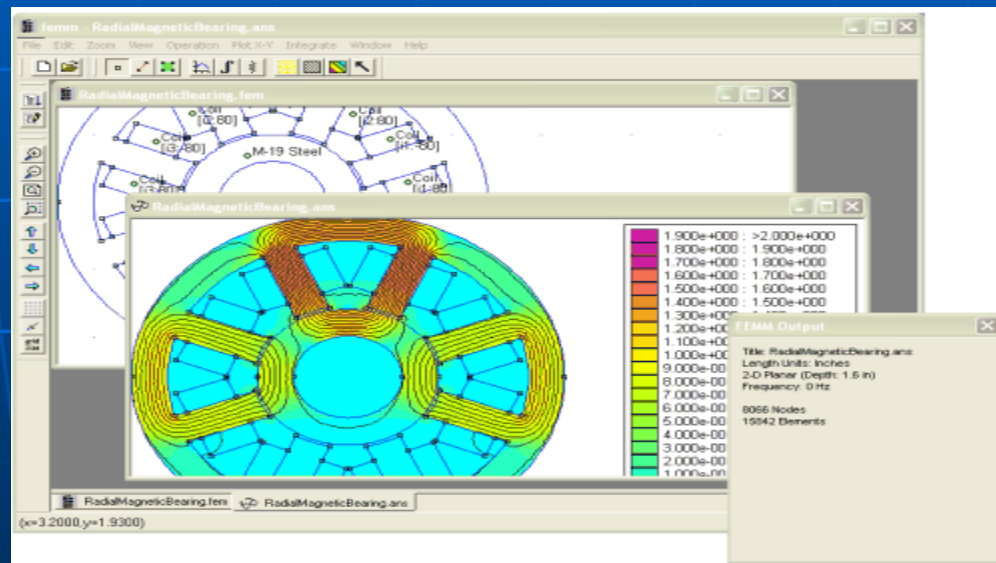

Finite Element Methods Magnetics

Nuclear Engineering

- The analysis of the concrete reactor bodies
- Solution of the dispersal problem of the neutron groups

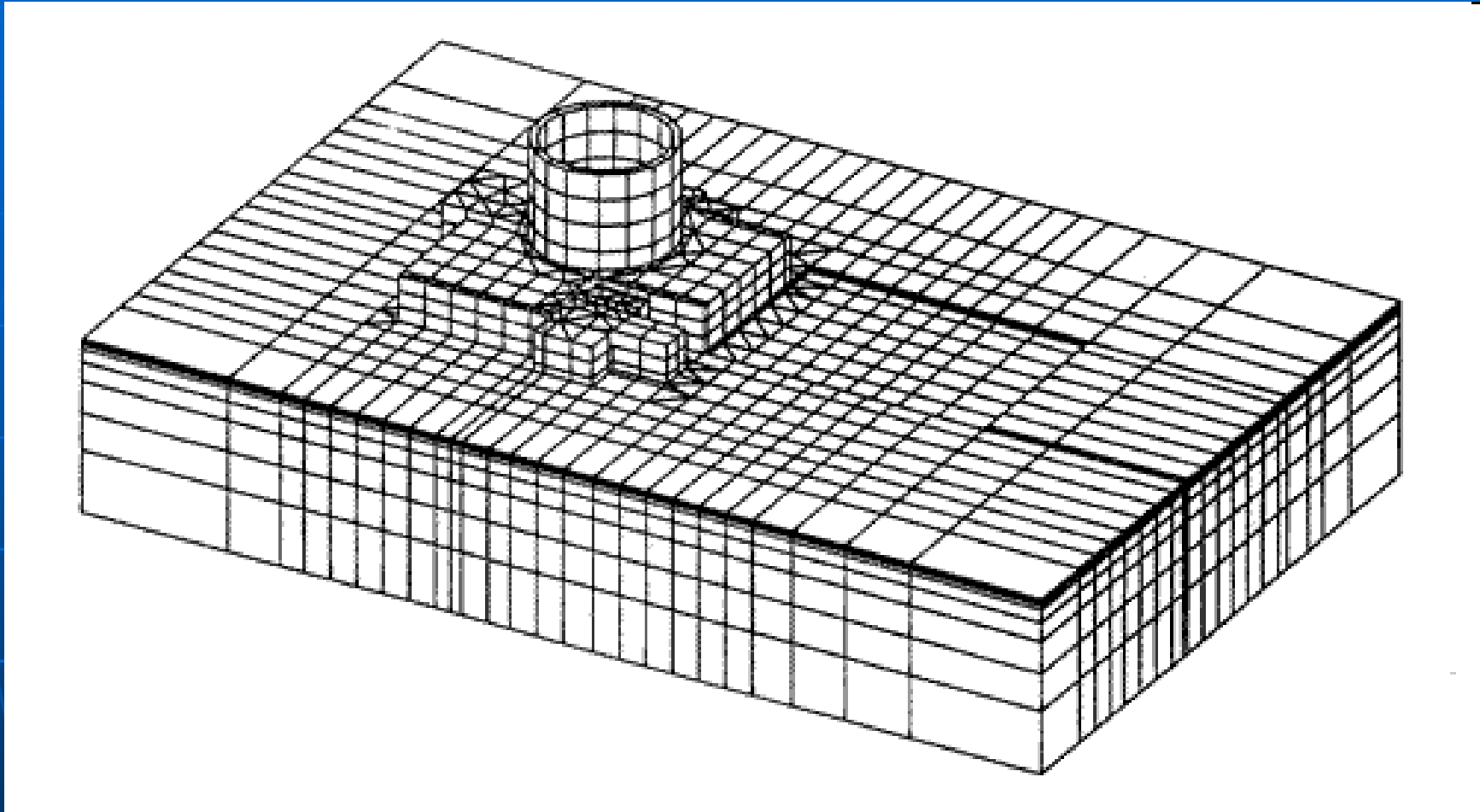

A nuclear power plant and its foundation

Aeroelasticity

- The load distribution of the surfaces having lifting property
- Analysis of the wing motions

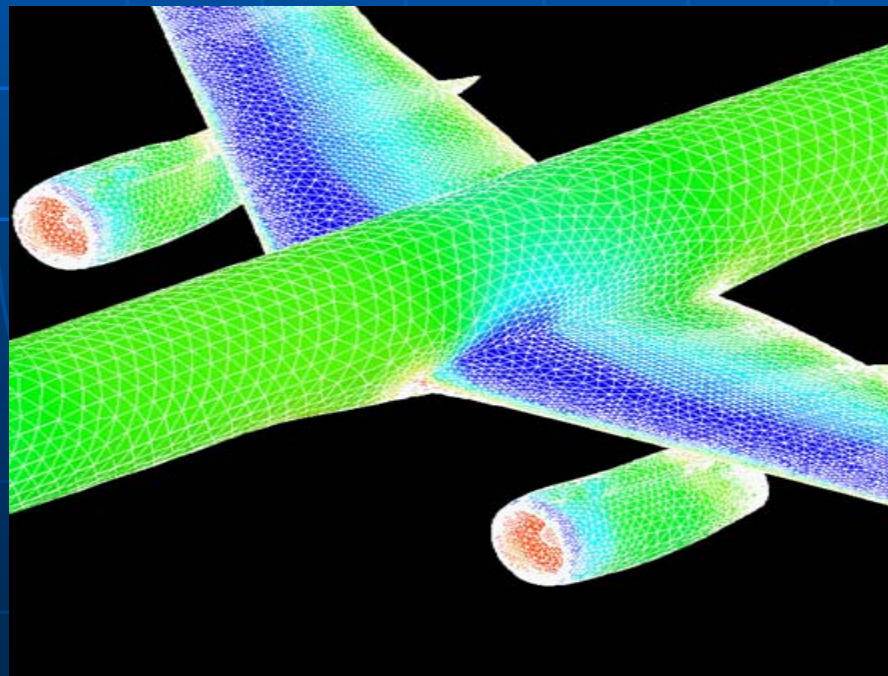

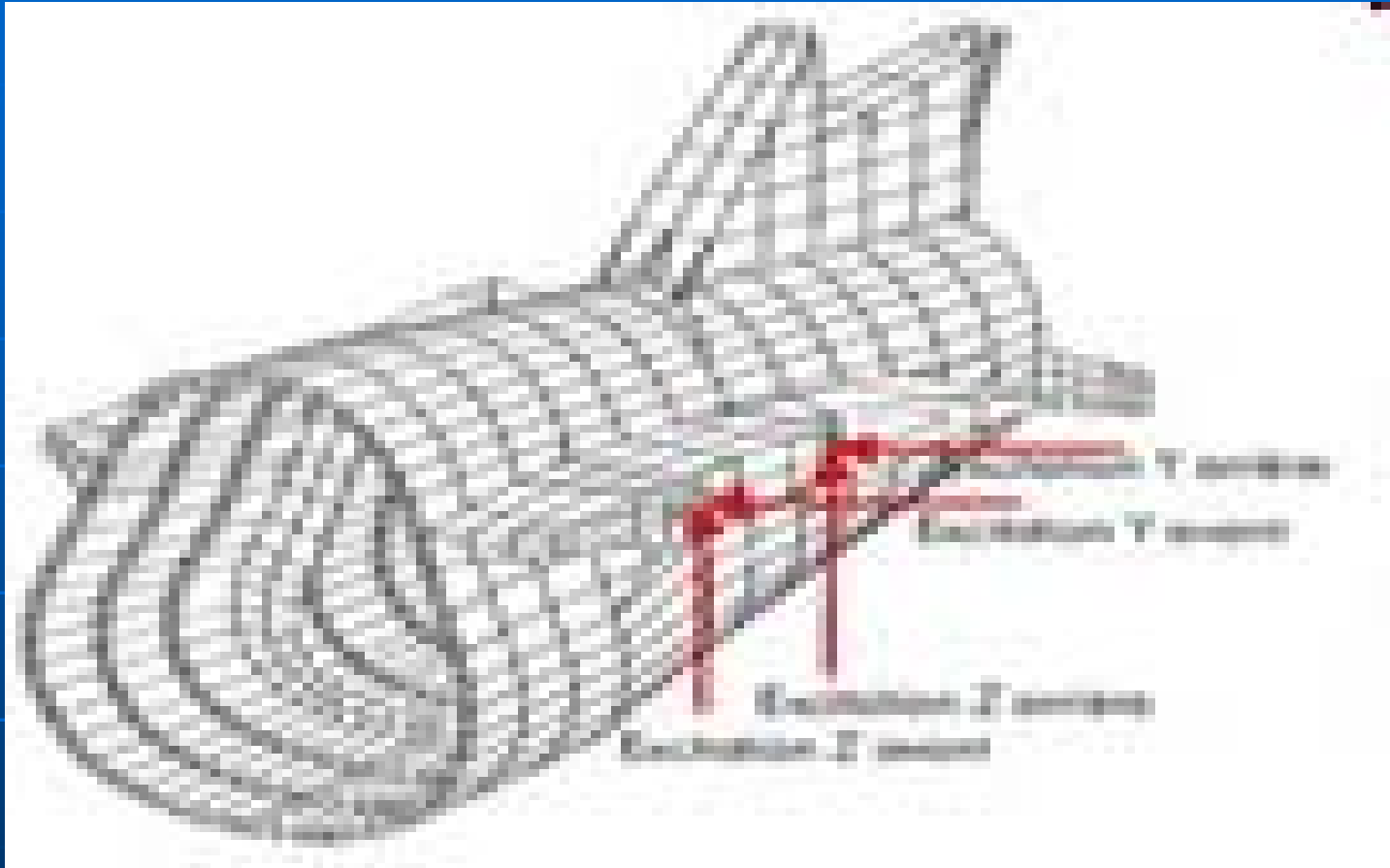

Model of Fixed-Wing Aircraft

Biomechanic

- The analysis of motions of the red blood vessels and plasma in capillary vessels.
- The tension analysis of the heart.
- The tension analysis of the bones and lubrication analysis of the joints
- The analysis of the head

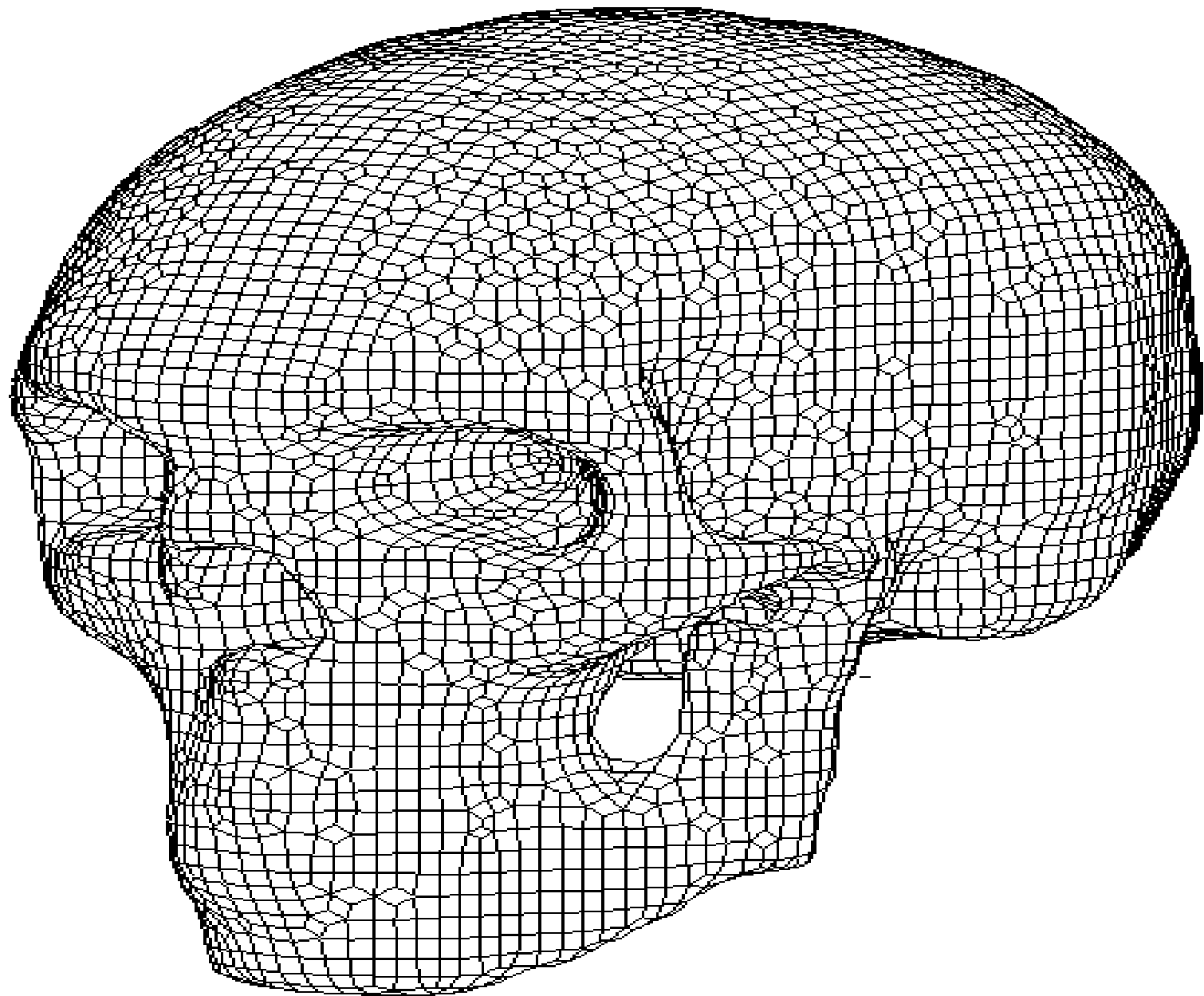

Finite Element Skull Model

Other important fields

- Composite materials
- Mechanism
- Metal Forming
- Magnetohydrodynamic
- Ship construction
- Etc.

66

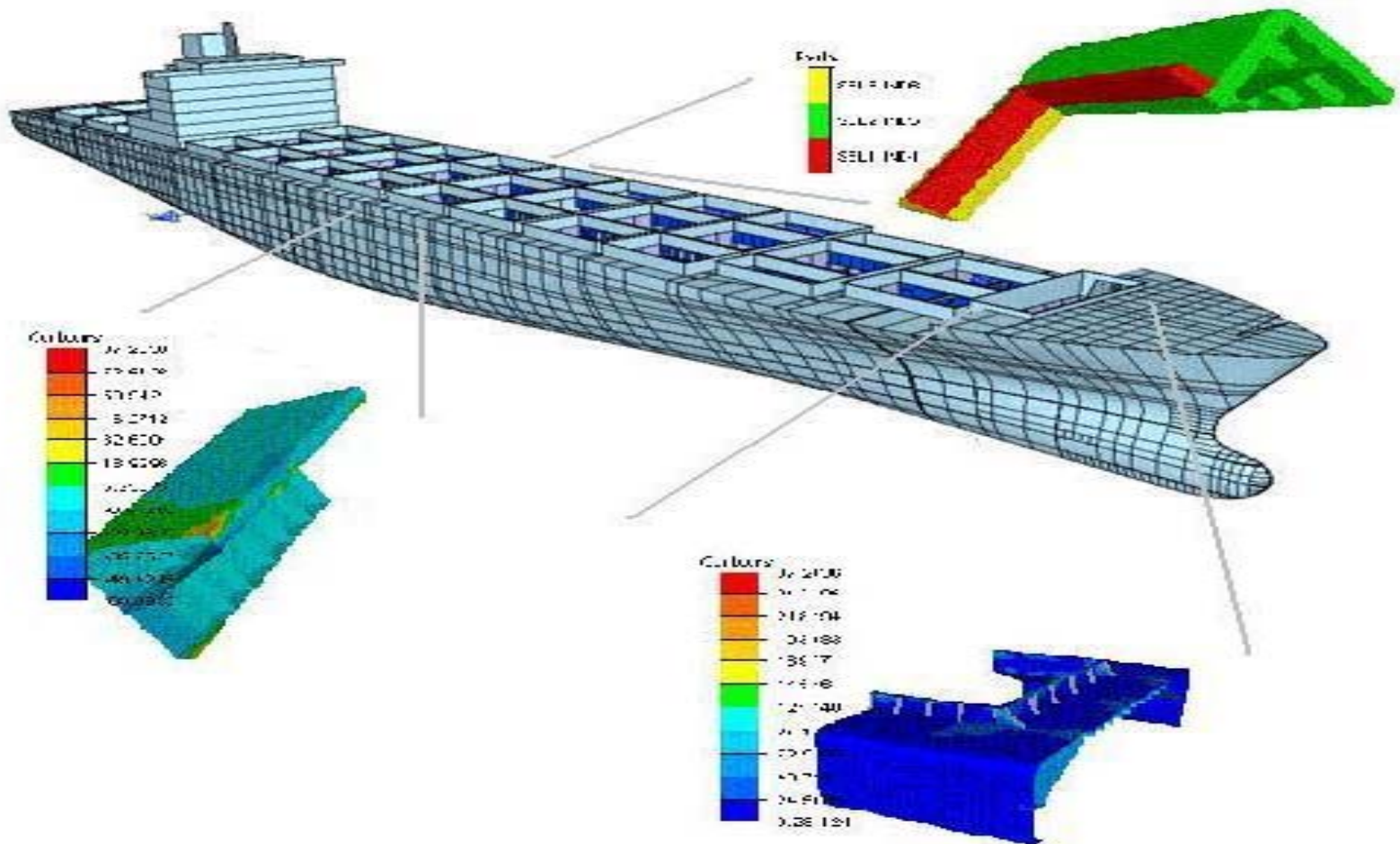

Courtesy of DNV Software

Finite Model of Ship construction

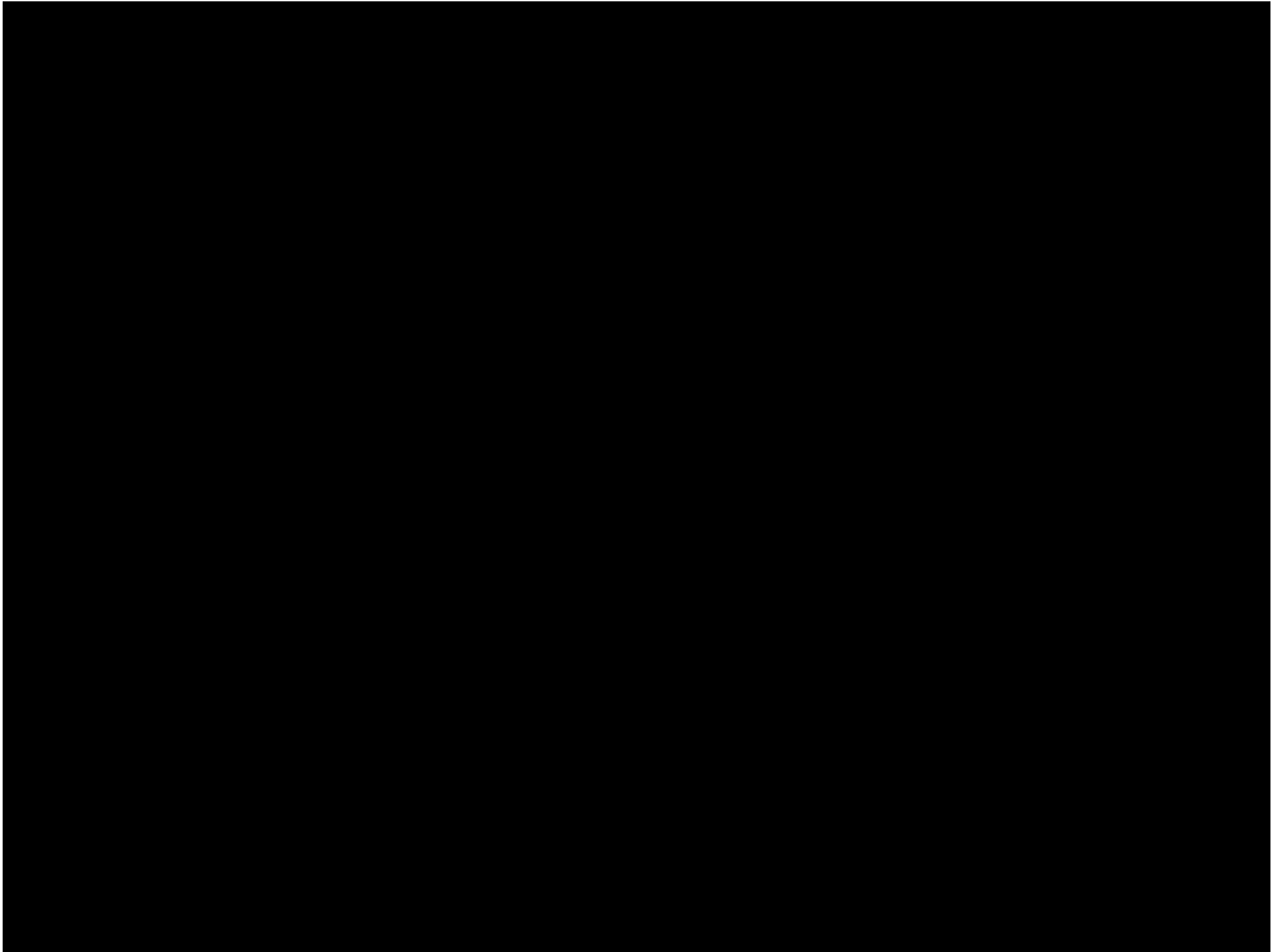

REFERENCES

- *Arikan, S., METU, Application Fields of Finite Element Methods*
- *Wikipedia, The Free Encyclopedia*
- *www.fea-optimization.com*
- *illustrations.marin.ntnu.no*
- *www.public.asu.edu*

Thank you for your attention..

Any question or comment?